

solo[®]

142/154

Instruction manual
Original instructions

Brushcutter

Important!

Read this instruction manual carefully before first operation and strictly observe the safety regulations!



Instruction manual

Original instructions

 **Caution!** Prior to operating the unit, please read the owner's manual carefully, and most importantly, observe all safety rules.

Observe the maintenance guidelines closely to ensure the long service life of your equipment.

Your dealer will be glad to assist you with any questions.

EC declaration of conformity → The EC declaration of conformity on a separate piece of paper forms part of these operating instructions.

Packaging and disposal

Please keep the original packaging in order to protect the equipment against transport damage in case you ever need to ship it or transport it. If the packaging materials are no longer required then they must be disposed of properly in accordance with applicable local regulations. Cardboard packaging materials are raw materials which can be recycled or reused.

At the end of the equipment's service life, please make sure that you dispose of it properly, in accordance with the official directives and regulations that apply in your area

In the best interest of continued technological progress we reserve the right to change the design and configuration of any product without prior notice.

For that reason, no claims can be accepted with reference to text and illustrations in this manual

Symbols/ type plate

The following symbols are used in this manual and on the product:

-  Thoroughly read these operating instructions before undertaking any maintenance, installation and cleaning steps

-  Wear ear defenders and a face shield before starting the engine

-  Wear protective gloves when handling and working with the equipment

-  Wear solid shoes, preferably safety shoes with a good tread

-  Always handle this power tool with particular care

-  Maintain a minimum distance of 15 metres bystanders

-  Please note: objects may be thrown out and high

-  Please note: power tool may kick back on contact with a solid object

-  Never exceed the specified maximum speed

-  Never smoke near the power tool or where the equipment is refuelled!

-  Keep open flames away from the power tool and the fuel can

- 
 - This equipment produces exhaust fumes and
 - fuel vapours are poisonous;
 - never start or refuel in enclosed spaces

Type plate:



- a: Type designation
- b: Serial number
- c: Build year (07 → 2007)

	Page
1. Safety regulations	4
1.1 <i>Correct use / General safety instructions</i>	4
1.2 <i>Working clothes</i>	4
1.3 <i>Fuelling</i>	5
1.4 <i>When transporting the equipment</i>	5
1.5 <i>Preparing the equipment for starting</i>	5
1.6 <i>Starting</i>	5
1.7 <i>Working with the machine</i>	6
1.8 <i>Maintenance and repairs</i>	6
2. Specification	7
3. Standard delivery	8
4. Control and function elements	8
5. Preparing the equipment for use	8
5.1 <i>Installation - Bicycle handlebar</i>	9
5.2 <i>Shield installation</i>	9
5.3 <i>Cutter installation</i>	10
6. Fuelling	12
6.1 <i>Fuel information</i>	12
6.2 <i>Fuelling</i>	12
7. Starting / Stopping the engine	12
7.1 <i>Half throttle start position</i>	12
7.2 <i>Choke and primer</i>	12
7.3 <i>Starting</i>	13
7.4 <i>Turning off the engine:</i>	13
7.5 <i>Engine will not start:</i>	13
7.6 <i>Additional notes on correct handling of the starter</i>	13
8. Using your brushcutter.....	14
8.1 <i>Scope of Application</i>	14
8.2 <i>Dual carrying shoulder strap</i>	14
8.3 <i>Correct brushcutter operation</i>	14
8.4 <i>Sharpening instruction for brush blade</i>	15
8.5 <i>Information regarding the line head (available as accessory)</i>	15
8.6 <i>Information regarding the chisel tooth blade (available as accessory)</i>	15
9. Operating and maintenance instructions	16
9.1 <i>General operating and maintenance instructions</i>	16
9.2 <i>Gearbox lubrication</i>	16
9.3 <i>Information about the silencer</i>	16
9.4 <i>Carburettor adjustment</i>	17
9.5 <i>Air Filter Maintenance</i>	17
9.6 <i>Information about the spark plug</i>	18
9.7 <i>Replacing the fuel filter</i>	18
9.8 <i>Shutdown and storage</i>	18
9.9 <i>Scheduled maintenance</i>	19
10. Accessories.....	20
11. Guarantee.....	21
12. Parts subject to wear and tear	21
* For USA only: Emissions Control Warranty Statement / Manufacturers Warranty Coverage	21
* Notes on the double shoulder belt	refer to the last two inside pages of this operating manual (after the Dutch section)

1. Safety regulations

1.1 Correct use / General safety instructions

Only use brushcutters fitted with the 3-tooth brush cutting blade for mowing grass, light brush, reeds and uncultivated growth at ground level. Never use the brushcutter for any other purpose (section 8.1 "Scope of Application").



Read the operating instructions carefully before placing in service and keep them in a safe place.

Use this power tool with particular caution.

Non-observance of safety instructions can lead to a risk to life. Also observe any regulations from your professional body. These operating instructions must always be available at the place of work. All individuals instructed to work with the equipment (including maintenance, care and repair), should read these instructions.

- You should request and receive instructions from the vendor on the safe operation if you are using this type of product for the first time.
- Children and young people under 18 years may not work with this power tool, with the exception of young people over 16 years of age who are being trained under supervision.
- Keep bystanders and animals away from the working area. Maintain a minimum distance of 15 m. When working near thickets, be aware that children and animals may be hidden there. Immediately stop the machine and the cutter if any person or animal comes close to the working area. The operator is responsible for any accidents or damage caused to parties or property.
- The device must only be lent, hired or passed on to persons who are familiar with this type of tool and who have read the operating instructions and know how to use the tool. Always pass on both sets of operating instructions together with the tool.
- Ensure you are rested and in good health when using this machine.
- Persons under the influence of alcohol or drugs, including prescription drugs, are not allowed to use this machine, as their ability to quickly react to potential danger may be impaired.
- Never alter, change or modify any safety equipment or functional assemblies on this machine.
- Only use this machine if it is in good, safe condition. Always check the machine prior to use. **Risk of accident!**
- Only use those accessories and attachments that have been supplied by the manufacturer and that are expressly approved for attachment. When using a nylon head, never replace a plastic line with a steel line. Always use the appropriate contact protection with each cutter.
- Always stop the engine and remove the spark plug cap when changing cutters to prevent unintentional starting of the engine.
- The reliability and safe operation of your machine depend on the quality of parts used with the machine. Only use original spare parts. Original spare parts are identical with genuine production parts and guarantee best quality in material, dimensions, function and safety. Original parts and accessories are available from your specialist dealer. Your dealer has been supplied with appropriate documentation to determine the correct parts. Your dealer is frequently supplied with updates about improvements to the equipment. Please note that the use of non-original parts will void your warranty.
- Always store the machine in a safe place and in such a way that it will not pose any danger. Stop the engine when the machine is not used.

Persons who disregard safety instructions, operating or maintenance instructions may be liable for any damage or consequential losses.

1.2 Working clothes

To prevent injuries, always wear suitable clothing and safety equipment when working with this power tool. This clothing should be practically oriented to the application (for example a tight fitting work suit), but should not be confining.

We recommend: **SOLO forest and countryside work jacket EN 340** Part no: 99303000 + size (2[s] - 6[xxl])

SOLO Outdoor Knee-breeches Part no: 9902095 + size

or **SOLO Outdoor dungarees** Part no: 9902094 + size

Never wear scarves, ties, jewellery or other items of clothing, which might get caught in the equipment, in brush or on branches. Safely tie back long hair (use a cap, helmet or similar).



Wear sturdy shoes with a good tread - ideally safety shoes.

We recommend: **SOLO leather forest boots** Part no: 9930510 + size (36 - 48)



Wear protective gloves with non-slip palms.

We recommend: **SOLO Fit** Part no: 9939012 + size.



Use ear defenders and/or a visor for protection against flying objects or objects caught up in the turbulence (protective goggles for example).

We recommend: **SOLO face/ear protection pack** Part no: 993901002 (one size)

1.3 Fuelling



Petrol is very light and highly flammable. Keep away from open flames and never spill fuel. Do not smoke at the operating site or at and near the refuelling site!

- Stop the engine prior to refuelling.
- Let the engine cool down before refuelling - fire risk!
- Open the tank lid slowly to allow any excess pressure in the tank to be reduced without the risk of petrol spraying out.
- Fuel may contain substances similar to solvents. Prevent products made from mineral oil coming into contact with skin and eyes. Wear protective gloves during filling with fuel. Frequently change and clean protective clothing.
- Avoid breathing in fuel vapour.
- The refuelling site should be well ventilated.
- Avoid any soil spillage of fuel or oil (protection of the environment). Use a suitable mat.
- Immediately clean any spilled fuel on the machine. Change contaminated clothing without delay.
- Firmly tighten all tank lids. This will reduce the risk of spillage from lids, which have become loose from engine vibrations.
- Check for petrol leaks. Do not start the machine or work with the machine if there is a petrol leak. Life threatening risk from burns!
- Store fuel and oil in approved and correctly labelled containers.

1.4 When transporting the equipment

- Always turn off the engine when transporting the machine.
- Never carry or transport the brushcutter with the engine running.
- Always cover the cutters with blade protectors, when transporting the equipment over longer distances.
- To prevent fuel running out and associated damages, secure the equipment against tipping over during vehicle transportation. Check the tank for leaks. It is advisable to drain the tank before transportation.
- Drain the tank before despatching the equipment.

1.5 Preparing the equipment for starting

Check the complete machine for operational safety.



- The stop switch should function properly.
- The throttle must have freedom of movement and return to the idle position on its own accord.
- The cutters and contact protection must be tightly secured and in perfect condition.
- Ensure the spark plug cap and the ignition cable are connected firmly. A loose connection may cause a spark, which can ignite any existing fuel:air mixture - fire hazard!

Should the check reveal any irregularities or recognisable damage (also to the frame), incorrect adjustments or reduced efficiency of the machine, do not commence work. Take the power tool to a specialised workshop and have it checked.

1.6 Starting

- Start the machine no less than 3 metres from the refuelling location. Never start the machine in an enclosed space.
- Ensure that you are standing firmly on the ground when starting. Always start on even ground, with a firm grip on the power tool.
- Only one person at the time may operate this power tool - no other people should be within a radius of 15 m - even when starting.
- Continue with the starting procedure as described in section 7. "Starting/Stopping the engine".

1.7 Working with the machine

- Only use this power tool when it is complete and in a safe condition.
-  As soon as the engine is running, the power tool generates toxic gases, which may be invisible and odourless. Never work with the power tool in enclosed spaces. In confined conditions such as pits or excavations, ensure adequate air changes during work.
-  Do not smoke at the work site and in the immediate vicinity of the power tool. There is an increased fire hazard!
- Work conscientiously, thoughtfully and calmly, and do not endanger third parties.
 - Pay attention to good visibility and lighting conditions.
 - Always remain within earshot of other people who can provide help in case of emergency.
 - Plan for timely work breaks.
 - Pay attention to possible hazards and take appropriate precautions. Be aware that wearing ear defenders reduces the ability to perceive noise. This includes sounds alerting to danger such as signals, shouts, etc. that can go unnoticed.
 - Exercise caution when the ground is wet or covered in ice and snow, on overhangs, or uneven terrain. There is an increased risk of slipping!
 - Pay attention to the risk of stumbling and obstacles, such as tree roots and stumps, edges, etc. Pay particular attention to safety when working on slopes.
 - Before commencing work, check the working area for stones, broken glass, nails, wire or other solid objects and remove such debris to prevent them being picked up and thrown out by the cutters.
 - Always hold this power tool firmly in both hands, and ensure your safe and solid foothold.
 - Always hold the cutters below hip level. Never lift a rotating cutter off the ground.
 - Keep all parts of the body away from rotating cutters.
 - Use a correct operating mode (see Chapter 8.3 "Correct brushcutter operation").
 - Use the power tool at lowest possible noise and exhaust levels. Only open the throttle when working, do not let the engine run unnecessarily. Please note that noise also impacts on the environment. Observe the quiet times that can vary from place to place.
 - Never use blunt cutters and avoid uncontrolled contact of the cutter with debris. Otherwise there will be an increased risk of the equipment kicking, which could throw the entire machine around. As a result, the operator could be subjected to involuntary movements, which could lead to serious injury or death.
- Stop the engine if you notice a difference in the operating characteristics of the brushcutter.
- Due to the centrifugal clutch, the cutters will run on for a short time, even if you release the throttle. Ensure the cutter has come to a full stop before storing the machine.
- Always stop the engine before any contact with the cutter – even when clearing a blockage or if cutters have become jammed – wait until the cutter has stopped and remove the spark plug cap.
- Never touch the exhaust or the silencer; as long as they are still hot, there is a risk of burns!
- Never work with a defective or missing silencer. There is a hazard of hearing damage and burning!

First Aid

A first aid box should always be available on-site. Immediately replace any materials you have used:

Note:

Over exposing persons with circulatory problems to vibrations can lead to damage to their nervous system or blood vessels. The following systems may occur from vibrations to fingers, hands or the wrists: Numbness, itching, pain, twinges, changes to the colour of the skin or the skin itself. Seek medical advice if you experience any of these symptoms.

1.8 Maintenance and repairs

Regularly service this machine. Only carry out those maintenance jobs and repairs, which are described in this manual. A specialised service centre will carry out all other jobs.

- Do not maintain, repair or store the machine near an open flame.
- Before cleaning, maintenance and repair work, always stop the engine first and pull the spark plug cap. Exceptions: carburettor and idle adjustments.
- For any repairs only use original parts from the manufacturer.
- Do not modify, alter or change the machine as this may impact on the safe operation of the machine and may lead to accidents and injuries!

2. Specification

Brushcutter		142	154
Engine type		SOLO single cylinder two-stroke engine	
Engine capacity	cm ³	40,7	54,2
Bore / stroke	mm	39 / 34	45 / 34
Engine power	kW at rpm	1,9 / 8000	2,3 / 8000
Max. permissible speed no load with cutter	rpm	11200 ± 300	
Medium idling speed	rpm	2700± 200	
Fuel tank capacity	l	0,7	
Fuel consumption at max. power (ISO 7293)	kg/h	1,02	1,25
Specific consumption at max. power (ISO 7293)	g/kWh	536	544
Clutch engagement speed	rpm	4200	
Fuel mix ratio: with SOLO 2T engine oil with other two-stroke oils		1:50 (2%) 1:25 (4%)	
Carburettor		All-position diaphragm carburettor with primer and integrated fuel pump	
Air filter		Fabric filter	
Ignition		Electronically controlled magneto ignition, maintenance free	
Gear reduction → Max. speed of the cutter	rpm	1,23 : 1 9100 ± 250	
Shaft tube - connection	Ø mm	30 Drive shaft Ø 7 mm / star serration 7 teeth	30 Drive shaft Ø 8 mm / star serration 9 teeth
Dimensions	mm	Height 530 Width 665 Length 1760	
Weight w/o shield and cutter	kg	8,3	8,3
In determining the following values regarding the acceleration of vibrations and sound, the different operating conditions were weighted in accordance with the current standards.			
Weighted effective acceleration a _{hv,eq} (DIN ISO 22867) Handle r.h. side / handle l.h. side	m/s ²	Brush blade 3-tooth 2,06 / 4,86 Nylon head 2,19 / 2,97	
Sound pressure level L _{Peq} (EN ISO 22868)	dB(A)	Brush blade 3-tooth 91,60 Nylon head 97,18	
Sound power level L _{Weq} (EN ISO 22868))	dB(A)	Brush blade 3-tooth 105,59 Nylon head 108,29	

3. Standard delivery

- **Brushcutter** partially assembled; the following components are supplied separately and require assembly
- **Bicycle handlebar**
- **Dual carrying shoulder strap**
- **Shield**, protective bar (line trimmer assembled) and all parts required to assemble the shield
- **Cutter**: brush blade 3-tooth
- All **assembly parts** required to fit the cutter
- **Tools**: combination spanner, retaining pin and screw driver
- **Instruction manual**, the **EC declaration of conformity** on a separate piece of paper

4. Control and function elements

Fig. 1

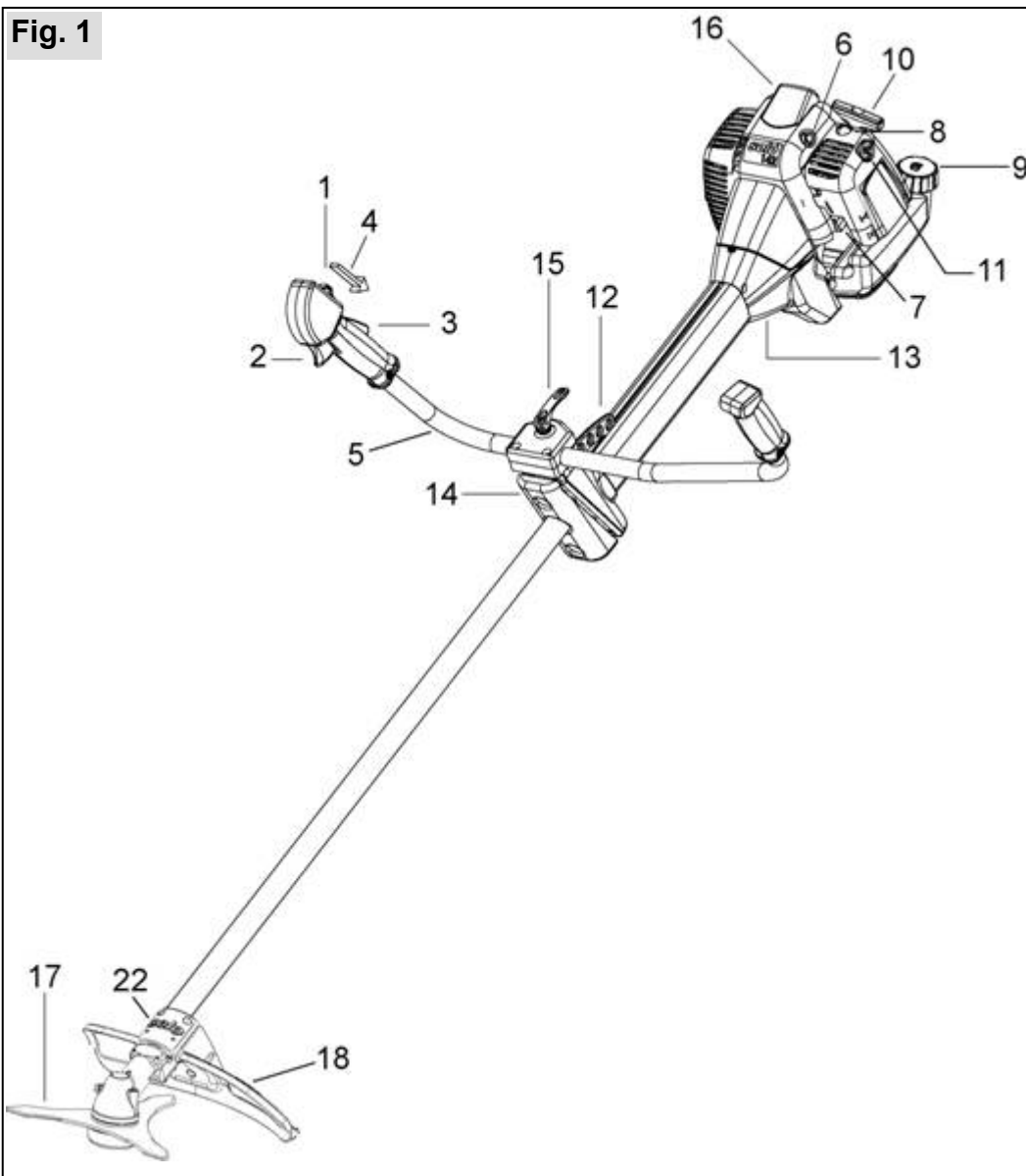

- 1 Stop-switch
- 2 Throttle lever
- 3 Throttle lock
- 4 Half throttle lock
- 5 Bicycle handlebar
- 6 Decompression valve
- 7 Choke lever
- 8 Primer
- 9 Fuel cap
- 10 Starter grip
- 11 Air filter cover
- 12 Harness rail
- 13 Anti-vibration system
- 14 Handle support
- 15 Quick acting tension screw
- 16 Sparkplug cap
- 17 Cutter
- 18 Shield
- 22 Retainer

5. Preparing the equipment for use

For shipping purposes, the brushcutter is partly disassembled and has to be reassembled prior to use. Only use the brushcutter after it has been fully assembled. Ensure that the tank is fully drained before any assembly, disassembly or modification.

5.1 Installation - Bicycle handlebar

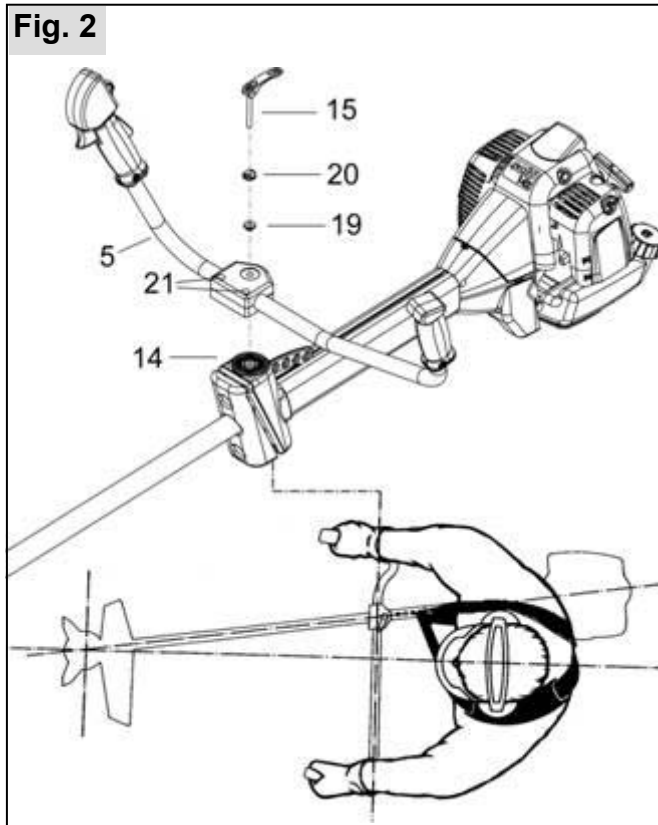

- Remove quick release screw (15) with sleeve (19) and wavy washer (20) from the handle support (14)
- Position the bicycle handlebar (5) with both pre-assembled half shells onto the handle support (14)
- Insert quick release screw (15) with sleeve (19) and wavy washer (20) into the handle support, but only so far that the quick release mechanism can still flip over when the handle is sitting tight.
- The r.h. side of handle should be fitted as near as possible to the handle support.
- For the optimum adjustment of the handle, flip quick acting lock upwards and, if necessary, release screws (21).
- Adjust the handle and flip quick acting lock (6) back again.
- Now tighten screws (21).

Note: You will have achieved an optimum adjustment, if the centre of the power tool is at the centre of your body. Your elbow should be slightly angled in operating position.

Important: Always lead the brushcutter with the bicycle handlebar on the r.h. side of the body!

5.2 Shield installation

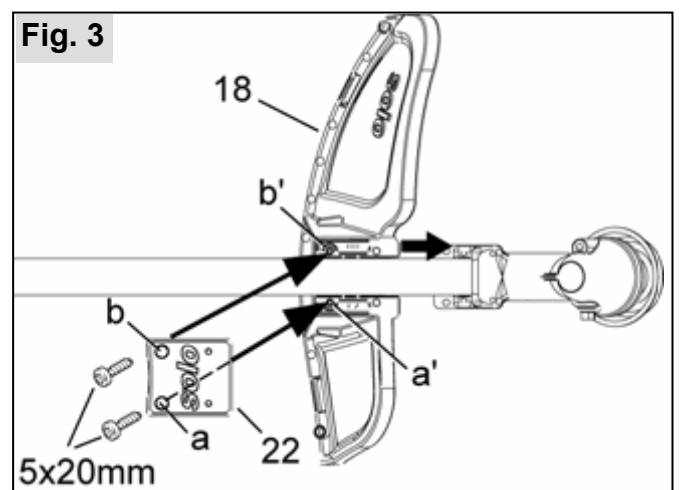

- Position the brushcutter with the output shaft facing downward.
- Raise the shaft tube and slide the guard (18) along the underside of the shaft tube into the correct position (it should reach a stop at the angular gearbox).
- Lay down the shaft tube with the guard.
- First insert a 5 x 20 mm bolt through hole **a** to tighten the retainer (22) on the guard. Then insert the second 5 x 20 mm bolt through hole **b**, tightening finger tight only at this stage.

(**Note:** The retainer has a raised part on the inside near hole **a**. This allows the first bolt (which is inserted through hole **a**) to be tightened straight onto the block without any risk of the connection not being straight.)

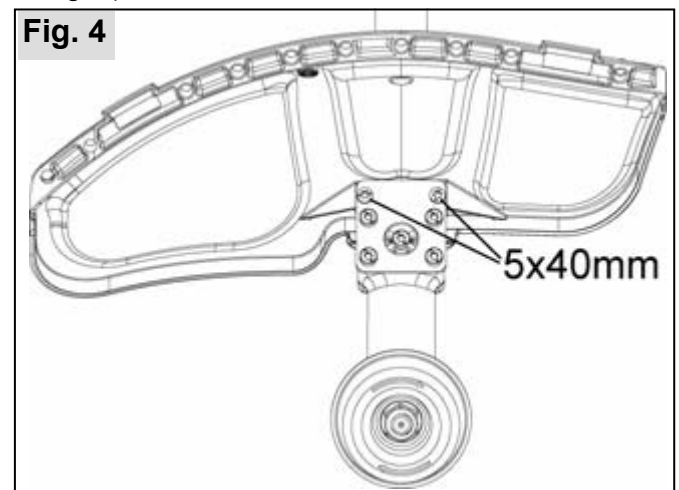

- Reposition the brushcutter with the output shaft facing upward.
- Insert the two long 5 x 40 mm bolts through the hole on the retaining bracket of the angular gearbox and tighten the guard and the retainer. The holes must line up exactly, so it may be necessary to adjust the position of the guard first.
- To finish off, fully tighten the bolt in hole **b**.

5.3 Cutter installation

Always switch off the engine, pull the spark plug cap and wear protective gloves when fitting or replacing the cutter!

A) Fitting the 3-tooth brush cutting blade and the 4-tooth grass cutter (available as accessory)

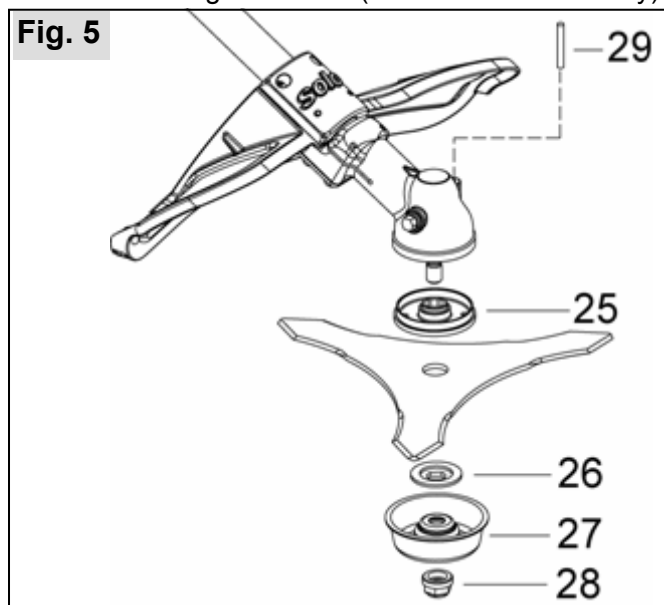

- Place the brush cutting blade on the pressure piece (25), ensuring that the cutting edges are facing in an anti-clockwise rotational direction (when looking at the tool in proper working position).
- Fix the pressure washer (26).
- Place the nut protector (27) and turn safety nut (28) onto the shaft.

Caution! Left hand thread - tighten counter clockwise.

Take care that all parts are centered.

- Block the shaft with the stop pin (4) and tighten nut.

 It is imperative that the safety nut (28) is replaced, if it has become loose due to frequent removal and tightening.

B) Fitting the chisel-tooth cutter (available as accessory)

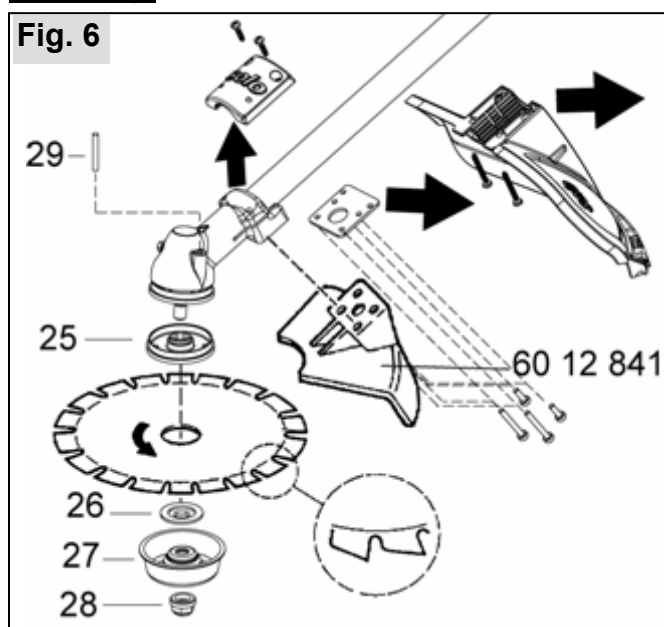

The procedure for installing the chisel tooth blade is similar to the installation of the 3-tooth brush cutting blade.

 When using a chisel tooth blade, always ensure that the metal guard (60 12 841) is fitted in place of the guard and the retaining bracket.

- Unscrew the guard together with the retainer.
- Unscrew the four bolts and remove the retaining bracket from the angular gearbox.
- Use the same four bolts to screw the metal guard (60 12 841) onto the angular gearbox.

Transport protection for metal cutting blades

When the metal cutting blades are attached, the transport protector must always be attached to cover the blades when the device is being stored or transported, or during work breaks during which the engine is switched off.

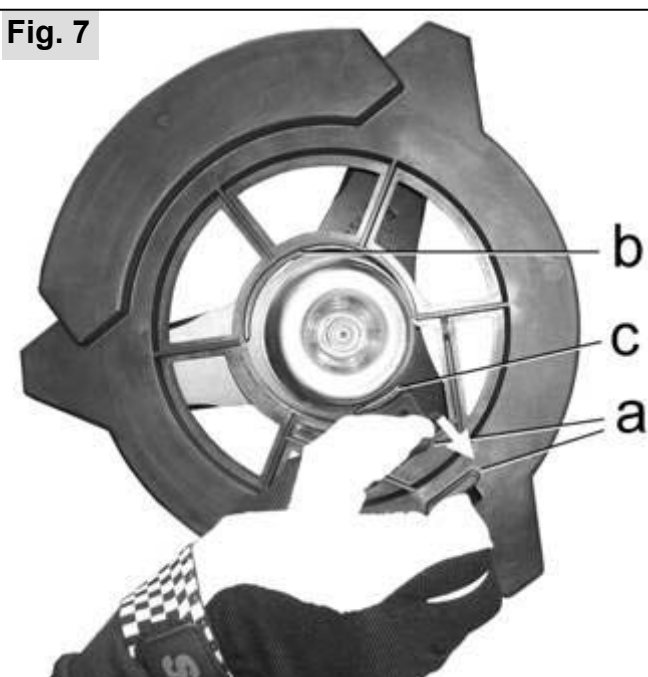

- Position the transport protector with the corresponding recess at one of the tips of the metal cutting blade.
- Press the two tabs (a) on the transport protector together to increase the internal diameter of the transport protector.
- Lay the transport protector right over the cutting tool. Position the inner shoulder (b) between the metal cutting blade and the running disc.
- Open the two tabs again, and in doing so also position the inner shoulder between the metal cutting tool and the running disc at tab (c).

When restarting work, take the transport protector back off by pressing the two tabs (a) together before starting the engine.

C) Installation of the nylon line head (available as an accessory)

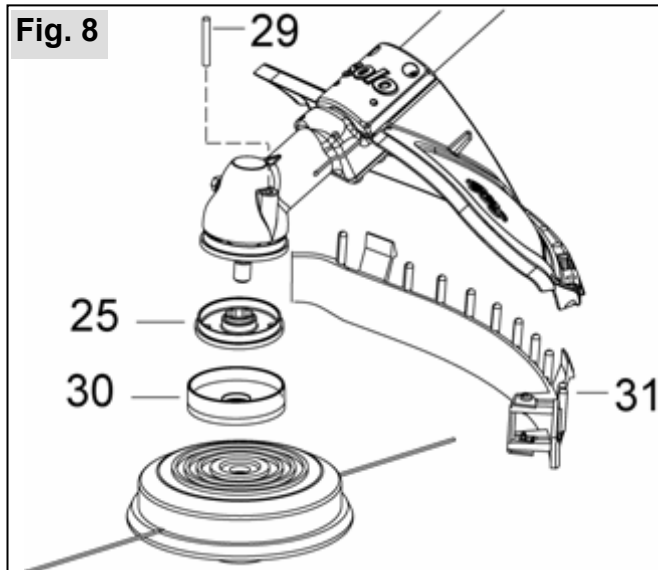

The following components should be removed when converting the brushcutter from the 3-tooth brush cutting blade to a nylon line head (see Fig. 5):
Retaining nut (28) (caution: left-handed thread), nut protector (27), pressure washer (26) and metal cutting blade.

- Fit the anti-winding protection (30) (supplied with the line head) after the pressure piece (25). The smooth side of the anti-winding protection faces the gearbox, with the edge of the anti-winding protection covering the edge of the angular gearbox.
- Block the shaft with the pin (29).
- Screw on the line head by hand. Caution: left-handed thread.
- Fit the protective bar (31) with assembled line trimmer from underneath onto the guard. Bend the protective bar slightly in the process.

Important: When using the line head, never start the brushcutter without the protective bar and the line trimmer assembled.

If the length of the line has been adjusted (see chapter 8.5, "Adjusting the cutting line"), the line trimmer will automatically cut the ends of the line to the correct length during operation.

When using metal cutting blades, always work without the protective bar fitted.

C) Assembly of the "Jet-Fit " cutting head



Insert the cutting line into the main body of the cutting head in accordance with the arrows on the main body. Insert enough line so that approx. 20 mm of the cutting line protrudes from the opening on the

opposite side.

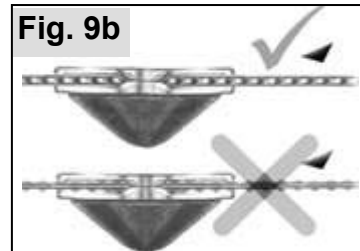

Make sure that the cutting teeth are correctly aligned in the direction of rotation.

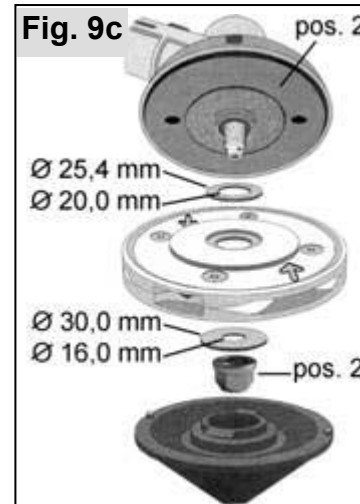

Various washers are supplied with the cutting head. For installation on this type of brushcutter, use exactly the washer dimensions shown in the illustration (outer diameter, inner diameter).

Block the shaft with the pin (29) and tighten the nut (28). Check that the cutting head is securely seated and properly centred.

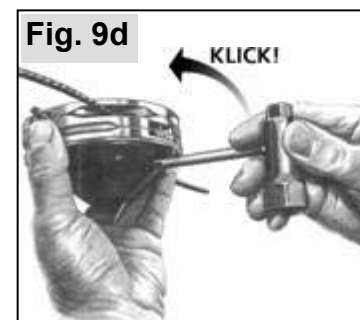

Fit the cover of the cutting head in place, turn it in the direction of the arrow and tighten it with the combination wrench as shown in the illustration until it engages.

When using the "Jet-Fit" cutting head, always use the standard guard and the assembled protective bar.

Cutting lines must not touch the guard during rotation. If necessary, insert the cutting lines slightly further into the main body of the cutting head. The line trimmer which is assembled in the protective bar is not suitable for cutting lines. → The length of the cutting lines needs to be manually adjusted to the correct length.

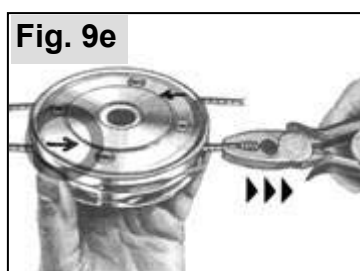

To replace a cutting line, pull the protruding end back out from the main body in the direction of the arrow (use universal pliers if necessary).

6. Fuelling

6.1 Fuel information

A high performance two-stroke engine operated with a petrol:oil mixture (petrol + oil = fuel mixture) or with a special fuel mixture for two-stroke engines available from specialists powers this machine.

We recommend the proprietary "**Aspen 2-takt**" special fuel mixture. Please observe the special fuel manufacturer's instructions.

Information on individual mixing of the fuel mixture

Normal or super unleaded petrol can be used for individual mixing purposes (**minimum octane number 92 RON**).

When using a particularly high quality proprietary 2-stroke engine oil such as the "**SOLO Profi 2T-Motoröl**" which we supply, we recommend an oil:petrol mixing ratio of **1:50 (2%)**.

When using **other brands of 2-stroke oil** we recommend a mixing ratio of 1:25 (4%).

Only use **proprietary 2-stroke engine oil!**

Never store fuel mixture longer than 3 - 4 weeks.

Fuel mixture table

Petrol in litres	Oil in litres	
	SOLO 2T engine oil 2% (50 : 1)	Other two-stroke oils 4% (25 : 1)
1	0.020	0.040
5	0.100	0.200
10	0.200	0.400

Unsuitable petrol or deviations in the mixing ratio may lead to serious engine damage!



Avoid direct skin contact with petrol and avoid inhaling petrol fumes - health hazard!

6.2 Fuelling

While fuelling always follow all safety instructions and take all safety precautions.

Handle fuel only with the engine turned off. Carefully clean the area around the filler inlet. Place the machine with the fuel inlet pointing upwards.

Unscrew the tank lid and fill the fuel mixture up to the lower edge of the filler neck. Use a funnel with filter to prevent tank contamination. After filling the tank replace the tank lid and tighten firmly.

7. Starting / Stopping the engine

7.1 Half throttle start position

Fig. 10

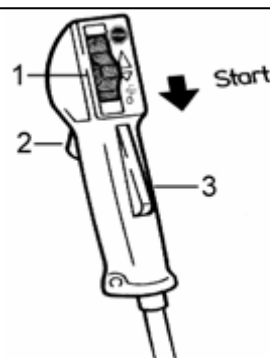

- Grip the handle; the **safety locking key** (3) is activated via the grip area, which also enables **throttle lever** (2) to be regulated.
- Press **throttle lever** fully down.
- Whilst holding the throttle lever down, move **stop switch** (1) towards "Start" (), and release the throttle lever.

The part throttle stop is cancelled by brief operation of the throttle control.

7.2 Choke and primer

Fig. 11

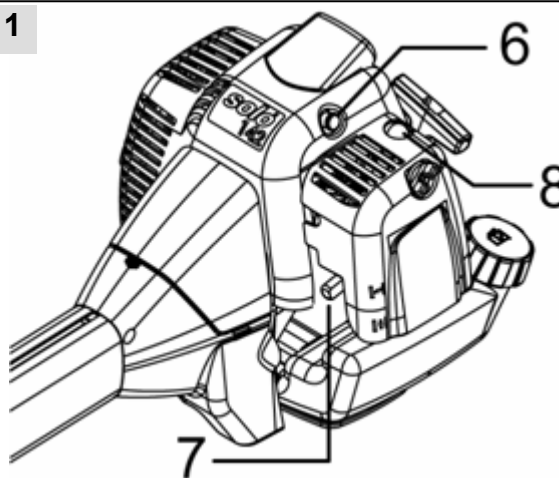

Adjust choke as follows:

- With a cold engine, position **choke lever** (7) up towards "Close" ←.
- With a warm engine, position **choke lever** (7) down towards "Open" ↓.

When first starting or if the fuel tank has been completely drained and has been refilled, press **primer** (8) several times (at least 5x) until the fuel is visible in the plastic bulb.

Press the **decompression valve** (6) every time before pulling on the starter handle to make the startup process easier. After starting, the decompression valve automatically returns to its normal position.

7.3 Starting

Observe the safety instructions when starting.

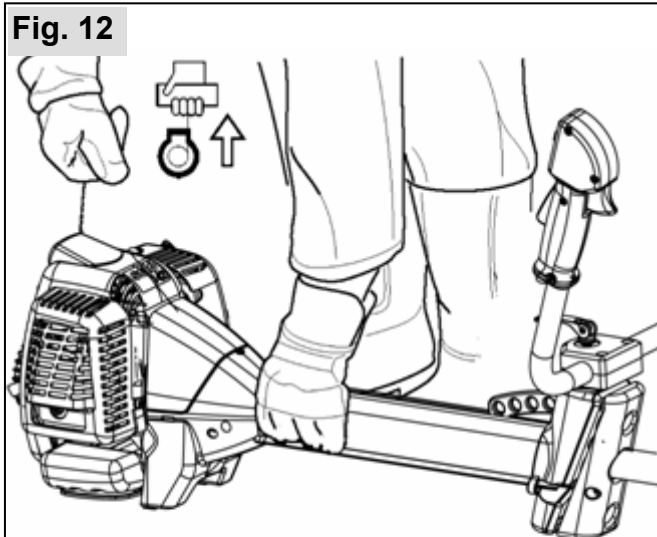

Lay the brushcutter level and without obstructions on the ground.

During starting, never stand or kneel on the shaft tube, otherwise the shaft or the tube might be damaged.

Take up a safe position, securely hold the machine and ensure that the cutter does not touch any objects or the ground.

When the engine is cold:

With the **choke lever** up (↑) and with the **decompression valve** held down, start the engine by pulling the starter handle up in a straight line several times until the motor is briefly audible (ignition).

Then immediately move the **choke lever** down (↓). Continue to start (with **decompression valve** held down) until the engine runs evenly.

When the engine is warm:

With the **choke lever** down (↓) and with the **decompression valve** activated, start the engine by pulling the starter handle up in a straight line several times until the motor runs evenly.

Note: Under good conditions, the engine will already start under idling throttle if it is at operating temperature. (If a part throttle stop is set it will be cancelled by operation of the throttle control even if the engine is at standstill.)

Starting with the **stop switch** in **mid-position**

If the engine will not start under idling throttle, set a part throttle stop in the way described above.

If the engine is running in part throttle operation:

briefly pull the throttle back to release the half throttle detent. Release the throttle lever again to allow the engine to run at idle speed. Now you can commence working.

7.4 Turning off the engine:

Release the throttle and push the stop switch to "STOP".

Important: Due to the centrifugal clutch, the cutter will run on for a short time, even if you release the throttle. Ensure the cutter has come to a full standstill before storing the machine.

Summary of the key points in the startup process:

- Position the engine safely on **level ground**,
- If necessary press the **primer** several times,
- Use the **stop switch** and the **throttle control** to set a part throttle stop.
- **Cold start:**
 - Set the **choke lever** to ↑, press the **decompression valve** and turn the engine until it fires for the first time,
 - Then set the **choke lever** to ↓,
 - Keep starting until the engine starts to run.
- **Warm start:**
 - Set the **choke lever** to ↓, press the **decompression valve** and start the engine until it starts to run.
- Once the engine is running, briefly pull the throttle control to cancel the part throttle stop.

7.5 Engine will not start:

If the engine fails to start after several attempts, check whether all adjustments described above have been correctly carried out, particularly that the stop switch is **not** in the "STOP" position. Try starting once again. The combustion chamber will be flooded, if the engine still fails to start.

In that case we recommend you proceed as follows:

- Remove the spark plug cover.
- Pull the spark plug cap off the spark plug.
- Remove the spark plug and dry fuel mixture from the electrodes.
- Move the throttle lever up to full throttle. Pull the starter handle several times (with removed spark plug) to clear the combustion chamber.
- Move the throttle lever down to idling position, refit the spark plug, the plug cap and the plug cover.

Start the engine with the choke lever down (↓) and the stop switch in the "Start" position.

7.6 Additional notes on correct handling of the starter

The following instructions are aimed at increasing the service life of the starter rope and of the starter mechanism:

- Always pull the rope out in a straight line.
- Do not let the rope drag across the edge of the rope eyelet.
- Do not pull rope all the way out - risk of the rope breaking.
- Always manually guide the rope back into its start position with your hand on the starter grip - do not let it retract on its own.

A specialist can replace a damaged starter rope.

8. Using your brushcutter

8.1 Scope of Application

Only use brushcutters fitted with the 3-tooth brush cutting blade for mowing grass, light brush, reeds and uncultivated growth at ground level.

Never use the brushcutter for any other purpose.

Using the cutting tools, which are available as accessories and which are specified for certain tasks, enable the brushcutter to be used for those purposes specifically mentioned in the accessory instructions. Also observe the safety instructions in those accessory instructions.

Generally, use only the cutting tools authorised for use with this brushcutter. Always fit the contact shield specified for this brushcutter and cutting tool. If in doubt, contact your local SOLO dealer.

8.2 Dual carrying shoulder strap

Fig. 13

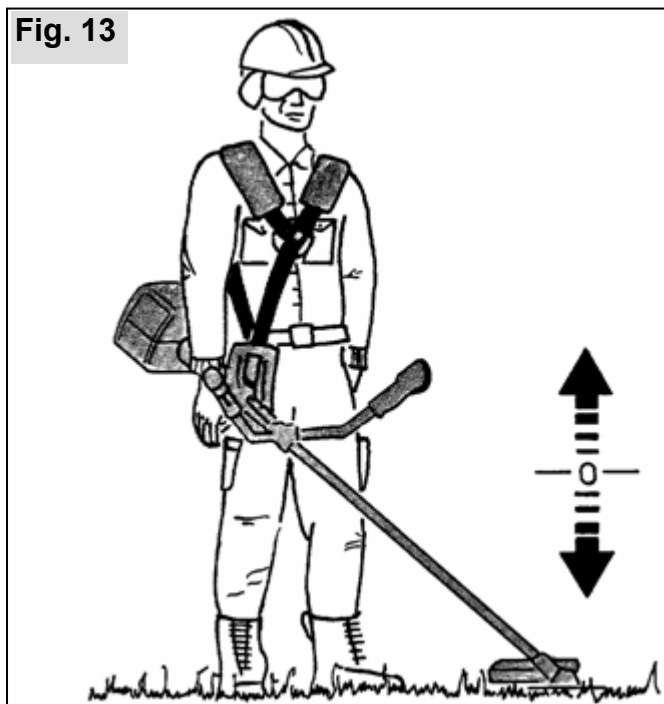

The brushcutter has to be balanced after the hook (Fig.1, pos. 12) is placed in the strap hanger. To balance the brushcutter the hook is hung in one of the various fastening holes. Release the strap on the respective hook.

When using the chisel-tooth circular saw blade, the shoulder strap should be adjusted so that the cutting attachment hangs freely, approx. 30 cm (12 in.) above the ground.

All other cutting units should lay flat on the ground without touching the brushcutter.

Notes on the double shoulder belt → refer to the last two inside pages of this operating manual (after the Dutch section).

8.3 Correct brushcutter operation

Observe the relevant safety instructions when using the brushcutter.

Fig. 14

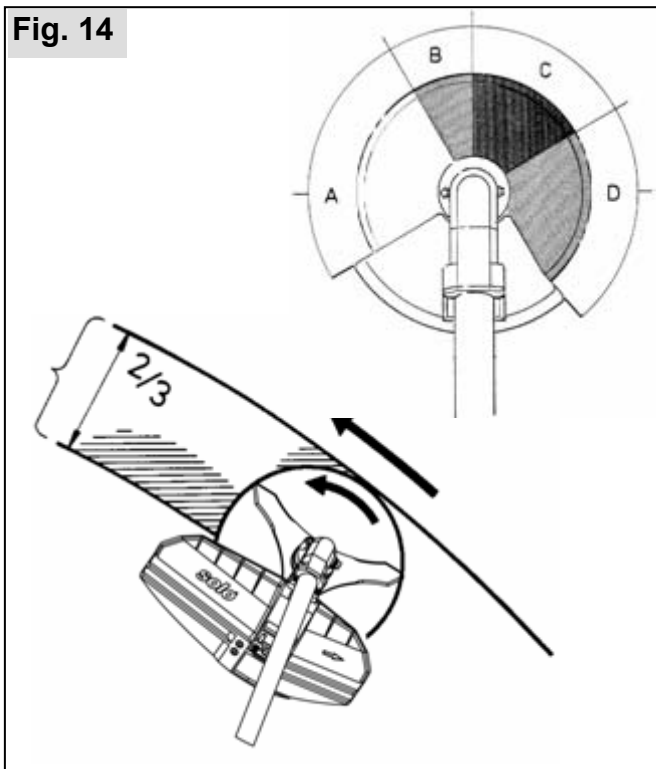

The rotational direction of the cutting tool makes the operation on the l.h. side of the cutting tool (from the operator's viewpoint, subject to the brushcutter being held correctly – section A) particularly free from kicking. Therefore, always approach the area to be cut from the right. This brings the l.h. side of the cutting tool into contact with the material to be trimmed first. Particularly when cutting tougher growth (such as medium sized weeds and wild growth), ensure that you do not "stab" the front of the brushcutter into the material to be trimmed.

Approach the working area with the brushcutter set to idle, and then switch to full throttle. Never leave the engine running at high speed without applying a load.

Dip the tool from the r.h. side 2/3 into the material to be trimmed. Then work the brushcutter like a scythe, i.e. by moving forward step by step, whilst cutting from right to left.

Operate the brushcutter at full throttle to obtain an optimum cutting result. Never operate with the clutch in slipping range. Consequential damage through excess loads or overheating is excluded from our warranty.

Immediately stop the engine in case of noticeable vibrations or when material has gathered around the cutting tool or contact shield. Slow down the cutting tool by pressing it onto the ground, until it has come to a complete standstill. Pull the spark plug cap from the plug, and clean the tool seat of all grass, roots etc. Check the entire brushcutter for perfect condition.

8.4 Sharpening instruction for brush blade

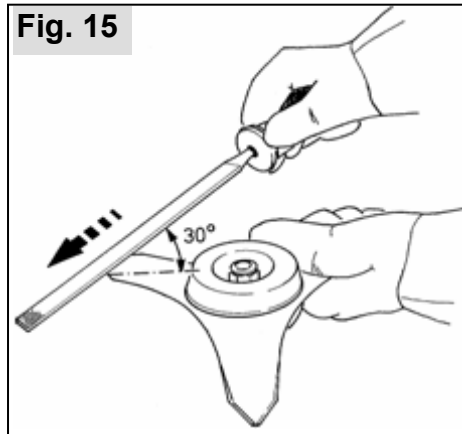

When dull, the cutter blade's edges can be re-sharpened on both sides with a flat file at an angle of 30°.

All cutting edges need to be filed back equally, if the wear and tear is substantial, or if there are broken-off cutting edges. It is necessary to check for imbalance and if necessary, to make corrections by additional filing. The sharpening angle is 30°.

8.5 Information regarding the line head (available as accessory)

When using the nylon head, always ensure that you operate only with the correct length of line. When the contact shield is fitted, the line will always be trimmed to the permissible length automatically (a line trimming blade is fitted into the shield). There is a high risk of injury, and the engine is subjected to excessive loads leading to a risk of damage, if nylon lines are left too long.

Therefore, when converting the cutting tool from grass cutter blade to nylon head, always fit the standard contact shield together with the protective bar and fitted line trimming blade.

Adjusting the cutting line

When using a semi-automatic nylon head:

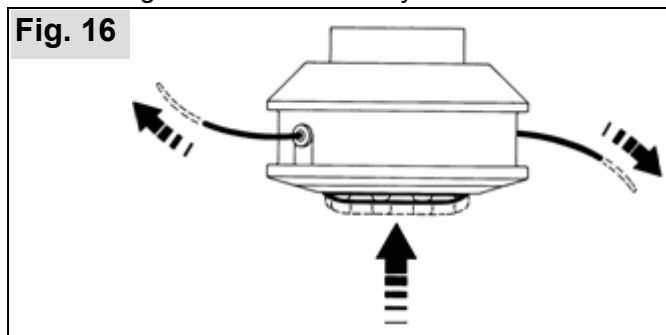

(schematic diagram)

Whilst the brushcutter is running without load, but with rotating nylon head, lightly push the nylon head several times onto ground with growth cover. The cutting line will be dispensed in stages. With each action, approx. 30 mm line will be dispensed. The line trimming blade will correct any excess length. When the cutting line is fully spent, you can replace it with line available Ø 2,4 mm under part no. 6900942 or Ø 3,0 mm part no. 6900974 (accessory).

8.6 Information regarding the chisel tooth blade (available as accessory)

The circular saw blade is only to be used together with the metal guard, Part No. 6012841. The blade is used for cutting bushes and trees up to 5 cm (2 inches) branch/trunk diameter.

For optimum cutting, the engine is accelerated to full throttle prior to making contact with the brush or tree. The cutting is done evenly without angling the cutting blade.

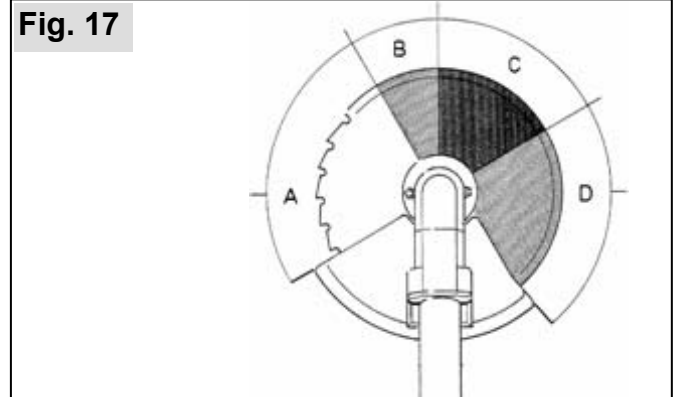

Work with the left stop edge (sector A).

⚠ Increased risk of accident and kickback exists in sector C. Solid material should not be cut in this sector.

⚠ There are work techniques for tree chopping which allow using sectors B and D. These are only to be utilized by professional operators since there is a potential for kick-back.

Sharpening instructions for Chisel-tooth circular saw blade

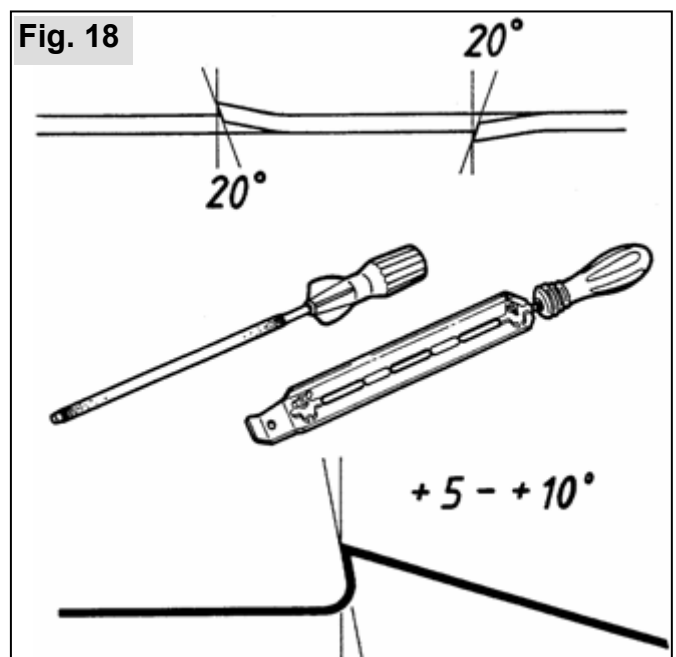

A dull circular saw blade can be sharpened with a 6.3 mm / 1/4" round file in a filing guide. Sharpening angle is 20° and clamping angle is 5°-10°. If the circular saw blade becomes worn, it is necessary to have it sharpened at a Service Center.

9. Operating and maintenance instructions

9.1 General operating and maintenance instructions

The maintenance and the repair of modern machines as well as their safety-relevant assemblies require qualified specialised training and a workshop equipped with special tools and test equipment. Consequently the manufacturer recommends that all tasks not described in these operating instructions be carried out by a specialised workshop. That specialist has the required training, experience, and equipment at his disposal, to provide you with the most cost-effective solution for such work. He will provide additional help in word and deed.

After a running-in time of app. 5 hours, all accessible screws and nuts (except the carburettor adjusting screws) must be checked for tightness and they must be retightened, if required.

Check the cutter regularly and whenever you notice any irregularities, or when the cutter/contact shield becomes blocked. For this, switch off the engine and wait until the cutter has come to a complete standstill. Pull the spark plug cap, and remove grass, debris, etc. from the cutter support. Immediately replace blunt or damaged tools, even if they display only small cracks – do a "ping" test.

It is best to store the equipment in a dry, safe location with a full fuel tank. There should be no open flame or similar nearby. For longer periods without using the equipment (longer than four weeks), see chapter "9.8 Shutdown and storage".

9.2 Gearbox lubrication

To lubricate the bevel gear drive, use SOLO "Special gearbox grease" (part no. 008318025). Check the grease level weekly and top up, if required (approx. every 20 - 50 hours).

Fig. 19

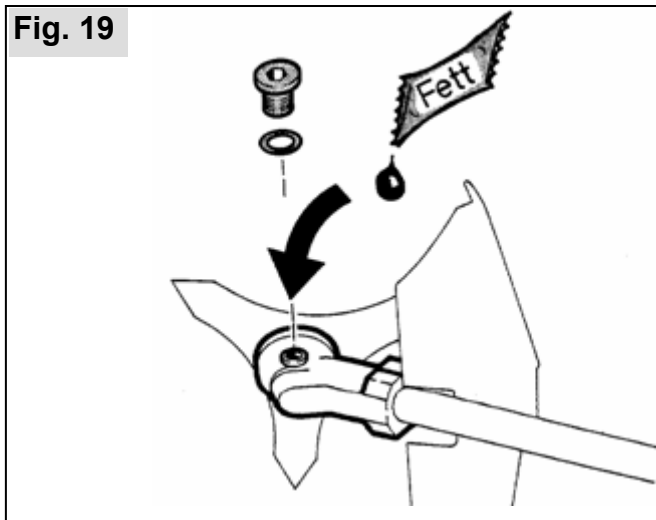

Remove the filler plug from the side of the gearbox. If no grease is visible inside, top up with grease (top-up quantity approx. 5 – 10 g).

Replace and tighten the filler plug.

Please note: Do not overfill with grease, as that may lead to the gearbox overheating. Never fill the gearbox casing to the top with grease.

Tip: If required, top up with a maximum of 5g grease. It is preferable to check more frequently (e.g. before you start working) whether grease is still visible. Your SOLO dealer workshop is happy to help you in case of doubt.

9.3 Information about the silencer

Ensure the silencer is in perfect condition before operating the machine. Never touch the silencer while it is still hot.

Unsatisfactory engine performance, despite a clean air filter and a correctly adjusted carburettor, may well be due to a partially blocked or damaged silencer. Please consult your specialist service centre.

9.4 Carburettor adjustment

The carburettor has been adjusted optimally at the factory. Subject to the operational altitude (mountains or low lying areas), the carburettor may require readjustment.

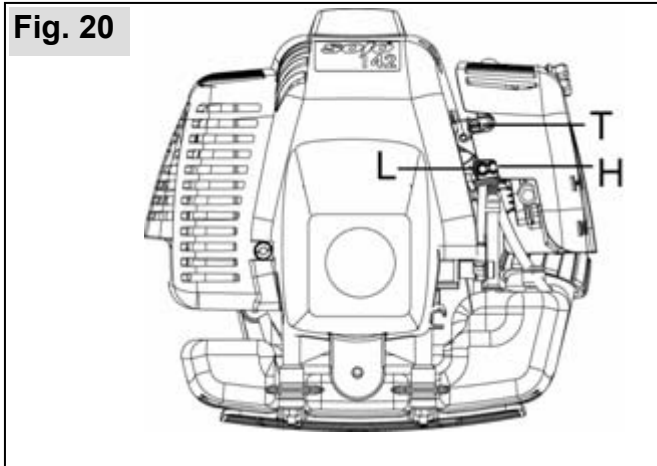

The carburettor has 3 adjusting screws:

- Idling end-stop screw "T"
- Low speed mixture screw "L"
- High speed mixture screw "H"

Only qualified mechanics must adjust the regulating screws for idle mixture "L" and full load mixture "H".

Turn the idling end-stop screw "T" to adjust the idling speed in accordance with the details provided in the specification. Use an engine rev counter for this job.

- If the idling speed is too high, turn the idling end-stop screw "T" anti-clockwise.
- If the idling speed is too low (engine stops) turn the idling end-stop screw "T" clockwise until the engine runs smoothly.

 With the throttle set to idle, the cutting tool must not, under any circumstances, rotate!

If the idling speed cannot be set correctly with the idling end-stop screw "T", request an authorised service centre to tune the carburettor.

The following instructions are for authorised service shops

D-CUT carburettors:

Use the D-CUT carburettor key to adjust the idle mixture screw "L" and the full load mixture screw "H".

Carburettors with limiter caps:

The regulating screws for idle mixture and full load mixture can only be adjusted in a limited range.

Clean the air filter before adjusting the low speed screw.

Let the engine run warm before adjusting the engine speed.

 The carburettor is tuned for optimum engine performance. Use a rev counter to tune the carburettor correctly!

Do not adjust the engine to a higher speed.

Excessive engine speed can lead to major engine damage!

9.5 Air Filter Maintenance

Contaminated air filters cause a reduction in engine performance and increase fuel consumption with more pollutants in the exhaust gas. Engines are less likely to start readily with a contaminated air filter.

Carry out the following maintenance jobs regularly.

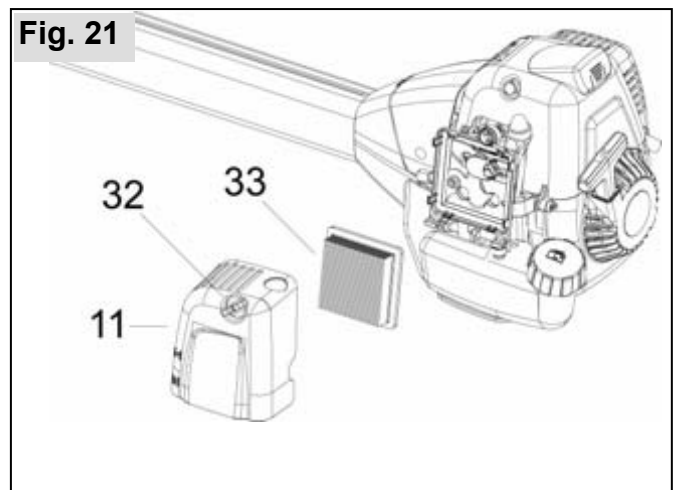

Before opening the air filter, close the choke  to prevent dirt entering the carburettor.

- Turn the wing screw (32) at the air filter cover (11) anti-clockwise.
- Flip the top of the air filter cover forward and remove.
- Remove the fabric air filter (33).
- Clean the area around the filter.

When using the equipment all day, clean the fabric air filter daily. Under extremely dusty conditions, clean the filter several times during the day as well.

Simply tapping the filter is the best cleaning method.

Never wash or clean the air filter with high compressed air or by wetting it; never place in an oil bath or into cleaning solution.

The air filter is blocked, if the engine speed noticeably drops when the carburettor is correctly adjusted. Under these circumstances, the filter needs replacing (part no. 20 48 154).

Low engine speed due to a blocked air filter must never be compensated by incorrect carburettor adjustments. This would cause the engine to overload, resulting in severe engine failure.

Engine failure caused by incorrect care is excluded from our warranty.

- Insert the new or cleaned fabric air filter into the casing.
- Position the air filter lid with the lower guiding pins onto the housing and push into place.
- Secure the filter cover by turning the wing screw (32) clockwise.

9.6 Information about the spark plug

Check the spark plug regularly after 50 hours of operation.

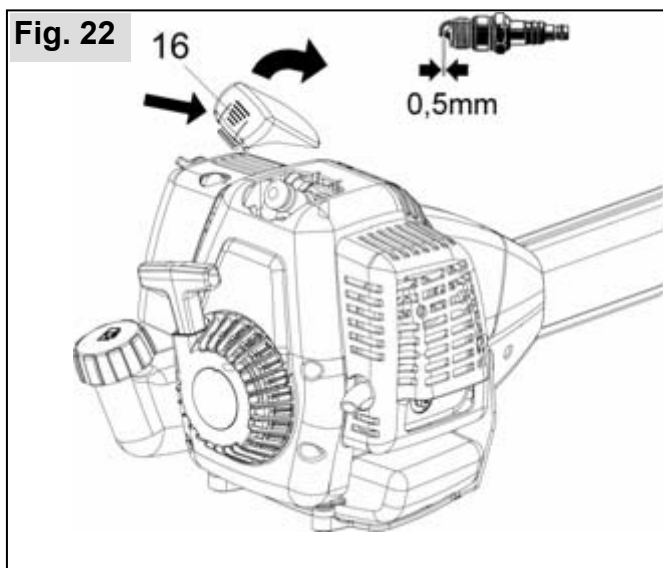

- Press the back tab of the spark plug cover (16) down and remove in an upwards motion.
- Disconnect the spark plug cap.
- Unscrew the spark plug and dry the electrodes.

The spark plug should be replaced after 100 hours of operation or if the electrodes are badly worn.

Do not turn the engine over while the spark plug has been removed or the spark plug cap has been disconnected from the high-tension ignition cable. A spark may cause a fire!

Spark plugs with resistor (thermal value 200) are available in different brands under the following description:

BOSCH WSR6F
 CHAMPION RCJ-6Y or comparable.

The correct electrode gap is 0.5 mm.

Only use spark plugs, where the contact nut has been firmly fitted. Loose connectors may produce sparks, which can cause a fire. Before restarting the engine, check the high-tension ignition cable for any damage to its insulation and ensure the cable is connected securely to the plug cap

- Insert the spark plug into the cylinder head and tighten it.
- Push the spark plug cap firmly over the spark plug.
- Position the spark plug cover onto the housing by aligning it with the guiding pins, push down and click into place.

9.7 Replacing the fuel filter

We recommend having the fuel filter (34) changed annually by a specialised service centre.



A trained mechanic can carefully remove the fuel filter via a wire loop through the fuel tank filler. Ensure that the thicker part of the fuel hose on the tank wall is not drawn into the fuel tank.

9.8 Shutdown and storage

Preferably, store the equipment in a dry and secure place with a full fuel tank. Open flames or similar must not be nearby. Prevent unauthorised use – particularly by children.

For stops longer than four weeks the following steps should be carried out:

- Empty and clean the fuel tank at a well-ventilated location.
- Start the engine with an empty fuel tank. Run the engine until the carburettor is empty and the engine stalls. Otherwise the carburettor nozzles could become encrusted with residual fuel mixture and make a subsequent start harder.
- Clean the power tool well (particularly the air intake openings, the cylinder fins, the air filter and the fuel filler area).
- Preferably, store the equipment in a dry and secure place with a full fuel tank. Open flames or similar must not be nearby. Prevent unauthorised access – particularly by children.

9.9 Scheduled maintenance

The following information is based on standard operating conditions. For special conditions, such as prolonged daily use, the recommended maintenance intervals should be reduced accordingly.

Implement all maintenance jobs regularly. If required, authorise a specialist service centre to maintain the machine for you. The owner of the machine is responsible for:

- Any damage caused by a lack of maintenance, incorrect or late maintenance and repairs
- Consequential losses - including corrosion - from incorrect storage

		after the first 5 hours	before starting work	weekly	after every 50 hours	after every 100 hours	as required	before the start of the mowing season, or once per year
Carburettor	Check idling speed		X					
	Adjust idling speed						X	
Air filter	Clean		X					
	Replace						X	
Spark plug	Check electrode gap and replace spark plug if required				X			X
	Replace					X	X	
Gearbox lubricant	Check			X				X
	Top up				X		X	X
Metal cutting blades	Check		X					
	Sharpen						X	
	Replace						X	
All accessible screws (except for adjusting screws)	Retighten	X					X	X
Controls (stop switch, throttle lever, half throttle detent, starter)	Check function		X					
Silencer	Visual inspection		X					
Complete machine	Visual inspection		X					
	Clean			X			X	X

Furthermore, as part of the annual service at an authorised dealer, request the following services:

- Complete check of the entire machine
- Professional cleaning of the engine (fuel tank, cylinder head fins, ...)
- Check and, if necessary, replace wearing parts, particularly the annual fuel filter change
- Optimum setting of the carburettor

10. Accessories

Via dealers, SOLO offers an extensive range of brushcutter accessories. Their use is limited to the particular model to which it is allocated, together with its relevant protection. Please refer to the following table for the correct accessories for models 142 and 154 and check with your retailer.

Accessory	Protection	Part no.
2 nylon head man. M 12 x 1.50 LI (grass, even around obstacles, light weeds)	Standard shield + protective bar, line trimming blade	6900630
2 nylon head semi-automatic M 12 x 1.50 LI (grass, even around obstacles, light weeds)	Standard shield + protective bar, line trimming blade	69006536
2 nylon head semi-automatic M 12 x 1.50 LI prof. (grass, even around obstacles, light weeds)	Standard shield + protective bar, line trimming blade	69006546
Replacement line for nylon head 15m, Ø2.4 mm		6900942
Replacement line for nylon head 15m, Ø3.0 mm		6900974
Spool of nylon cord 90 m, Ø2,4 mm		0063201
Grass cutter blade 4 teeth, Ø230 mm (grass, stronger weeds)	Standard shield	6900948
Brush blade 3 teeth Ø250 mm (bushes, reeds, tough grass)	Standard shield	6900947
Brush blade 3 teeth Ø300 mm (bushes, reeds, tough grass)	Standard shield	6900943
2-line-Cutter head "Jet-Fit" (bushes, reeds, tough grass, branches up to 20mm)	Standard shield + protective bar, line trimming blade	6900160
4-line-Cutter head "Jet-Fit" (bushes, reeds, tough grass, branches up to 20mm)	Standard shield + protective bar, line trimming blade	6900162
Replacement line for "Jet-Fit" cutter head 2.5 mm x 260 mm 50 pcs.		6900166
Replacement line for "Jet-Fit" cutter head 3,5 mm x 260 mm 25 pcs.		6900168
Replacement line for "Jet-Fit" cutter head 2,5 mm x 53 m		6900175
Replacement line for "Jet-Fit" cutter head 3,5 mm x 27 m		6900176
Chisel-toothed circular saw blade Ø 200 mm, incl. metal end-stop (<i>Bushes and trees up to 5cm trunk diameter</i>)	Metal end-stop	6900695
High performance gearbox grease		008318025
SOLO 2T engine oil 100 ml		0083103
SOLO 2T engine oil 1 l		0083104
SOLO 2T engine oil, in a metering bottle 1 l		0083105
SOLO face/ear protection pack		993901002
SOLO forest and countryside work jacket EN 340	99303000 + size (2[s] - 6[xxl])	
SOLO Outdoor Knee-breeches		9902095 + size
SOLO Outdoor dungarees		9902094 + size
SOLO leather forest boots		9930510 + size (36 - 48)
Gloves SOLO Fit		9939012 + size

11. Guarantee

The manufacturer guarantees trouble-free quality and will cover the cost of replacing parts which are found to be faulty in material or workmanship within the prescribed guarantee period after the date of purchase. Please note that specific guarantee conditions may vary from country to country. If in doubt, ask your equipment vendor. He is responsible for guarantee matters.

We hope you will understand that we cannot be liable for damage resulting from the following causes:

- Non-compliance with the operating instructions.
- Neglecting essential maintenance and repair work.
- Damage caused by incorrect carburettor adjustment.
- Wear in normal use.
- Obvious overload by continuously exceeding the maximum performance limit of the product.
- Using non-authorized tools.
- Use of force, incorrect treatment, misuse and accidents.
- Damage from excessive heat due to dirt build-up around the cooling fan housing.
- Attempted adjustments and repairs by unqualified persons.
- Use of unsuitable spare parts or third party parts, if these are the cause of the defect.
- Use of unsuitable or stale fuel.
- Damage caused by using the product in the hire or rental industry.

Normal cleaning, adjustments or maintenance work fall outside the guarantee provisions.

A service centre authorised by the manufacturer must carry out all guarantee work.

12. Parts subject to wear and tear

Various parts are subject to application-specific or normal wear and must be replaced in good time, when required. The following parts are subject to normal wear and are not covered by the manufacturer's guarantee:

- Air filter
- Fuel filter
- All rubber parts which come into contact with fuel
- Clutch
- Spark plug
- Starter
- Cutting tools



For **USA** only

Emissions Control Warranty Statement

The Environmental Protection Agency and Solo are pleased to explain the emission control system on your small non-road power equipment engine. In the US new small non-road engines must be designed, built, and equipped to meet the Environmental Protection Agency's standards. Solo must warrant the emission control system on your small non-road engine for the period of time listed below provided there has been no abuse, neglect, or improper maintenance of your small non-road engine.

Your emission control system includes parts such as the carburetor, the ignition system, and the exhaust system. Where a warrantable condition exists, Solo will repair your small non-road power equipment engine at no cost to you including diagnosis, parts, and labor.

Manufacturers Warranty Coverage

Solo's small non-road power equipment engines are warranted for a period of two years. If any emission control related part on your engine is defective, the part will be repaired or replaced by Solo.

Contact Information for Authorized Service Center Locations, Replacement Parts, Warranty and Technical Information

Warranty repairs **must** be completed by a SOLO Authorized Service Center.

SOLO USA, Inc.
5100 Chestnut Avenue
Newport News, VA 23605

1-800-765-6462
techserv@solousa.com

solo[®]

Made in Germany



SOLO
Postfach 60 01 52
D 71050 Sindelfingen
Tel. 07031-301-0
Fax 07031-301-130
info@solo-germany.com

SOLO
P.O.Box 60 01 52
D 71050 Sindelfingen
Germany
Phone+49-7031-301-0
Fax +49-7031-301-149
export@solo-germany.com